

ML-LCD-DMX MANUAL

The ML-LCD-DMX is a DMX-512 compatible controller designed for use with RGB/colour change lighting in environments where standard DMX control consoles are either unsuitable or unnecessary, such as domestic, retail, restaurants. With its full colour 2.0" display and simple 4-button keypad, the new controller allows for complete, effortless control of up to 8 separate areas, each area with its own colour, fading, speed and dimming options. The ML-LCD is best suited for use with ML-DMX-S (DMX slaves).

SPECIFICATIONS:

Power:	12VDC Nominal (9-14VDC) @ 500mA MAX
Input:	3-pin TTL Serial connector (reserved for testing/updates) DO NOT CONNECT
Output:	RJ45 DMX connector (note unique pinout configuration in CONNECTION/WIRING)
Interface:	4-Button keypad 2.0" Colour active matrix OLED display
Dimensions:	72mm wide 114mm high 15mm deep (face), 30mm deep (entire unit)

INSTALLATION:

The ML-LCD-DMX hardware is based around a HPM Excel series switch plate. As such it can be mounted to any standard mounting hardware that is compatible with the Excel series. The following diagram shows the screw locations and cut-out size required for mounting directly to a wall (note a metal retaining plate is recommended when fixing to plasterboard).

As it features no degree of weatherproofing, the ML-LCD-DMX must be installed indoors. For maximum safety and interference rejection no high voltages (greater than or equal to 240VAC) should be installed immediately beside the ML-LCD-DMX. If it is necessary to mount the ML-LCD-DMX next to another switch plate, ensure that the 240V is segregated appropriately. Mounting close to dimmer switches is not advised.

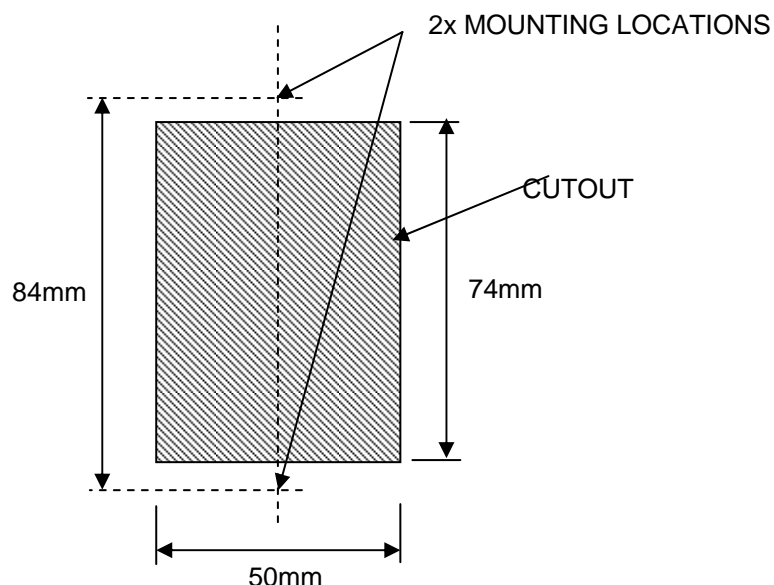

FIG 1: ML-LCD-DMX Mounting diagram

WIRING:

Wiring of the ML-LCD-DMX is very straightforward. The 12VDC power supply is wired directly into the green terminals marker *POWER 12VDC*, taking note of the marked polarity. The ML-LCD-DMX has reverse polarity protection and if the power supply is connected reverse polarity, the unit will simply fail to power up.

The DMX signal output is a standard 8-pin RJ45 connector. It is intended for use with standard cat5 UTP cables wired for straight through connection.

Note that cat5 cables wired for crossover connection will not work.

As there was no standard for the pins used for DMX over cat5 cabling at the time of design, a custom cable may need to be made in order to control any DMX slaves other than the M-Elec ML-DMX-S.

BASIC OPERATION:

All control of the ML-LCD-DMX is done using the 4-button keypad. The four buttons are located under each of the four corners of the diamond shape, and each is referred to by the direction that the arrow on that button is facing. The last line of the display always features prompts which give basic descriptions of what each button does (if that button has an applicable function).

Each button has a tactile feel to it when depressed, giving the user feedback that the button has indeed been pressed. Generally a button is simply pressed and released when navigating the menus, but when changing values buttons can be held down so that the value changes faster than usual.

The ML-LCD-DMX also features a reset button on the back of the unit, just above the DMX signal output RJ45 connector. This button is generally reserved for use by the installer so that they can switch the unit into setup mode, but can be used in the unlikely event of any problems to reset the system.

Immediately after power is applied, the ML-LCD-DMX will start operating. First, the start-up screen will be displayed for 5 seconds. Note that the software version number is displayed on the start-up screen – it may be necessary to provide this number when requesting technical support.

After the 5 seconds has elapsed, the screen will display the main menu and the user can begin operating the ML-LCD-DMX.

OPERATING TERM GLOSSARY:

DMX: The name of the industry-standard protocol used by the ML-LCD-DMX to send colour/fading information to slave units. Note that the slave addresses indicated on the ML-LCD-DMX do not correspond to true DMX addresses. As each slave has 3 outputs (one for each red, green and blue), the actual DMX address of the slave is the slave address multiplied by 3, then add 1 for the green channel or add 2 for the blue channel.

Master: The unit that controls all of the slave devices connected to it. A DMX network needs a master in order to control the fading patterns and speeds and send the correct data to the corresponding slave's devices.

Slave: A slave device is unable to control anything on its own. It simply performs the instructions commanded by a master controller. The ML-LCD-DMX can address up to 64 slaves, each of which has a red, green and blue output.

RGB LED: LEDs are the latest in lighting technology. By mounting a red, green and blue LED in close proximity to one another (or even in the same physical package) and controlling the brightness of each LED, effectively any colour possible can be generated. For example, red on, blue on and green off gives purple. All colours on full gives white. The M-Elec DMX system is designed primarily for control of RGB LED lighting.

Area: Exactly as the name suggests, an area is an area of a house/store/restaurant/etc. that can be controlled separately from other areas in the installation. The ML-LCD-DMX supports up to 8 separate areas.

Static Colour: Refers to the set colour of an area. Unless fading is turned on, the static colour will remain the same while ever the system is on.

Fade/Colour Fade: In the ML-LCD-DMX controller, fading refers to the automatic change between a preset set of colours. The rate at which the colours change is adjusted by the fade speed.

There are four different fading palettes:

- All colours: Fades through all possible colours
- Warm colours: Fades through reds, yellow, orange, etc.
- Cool colours: Fades through greens, blues and white
- Pastel colours: Fades through all colours but with pastel hues applied.

Dimming: Making the brightness of the lighting darker without changing the colour. The ML-LCD-DMX has 6 levels of dimming from none (0) to extreme (5). Dimming can be applied to both static and fading colours.

CONTROLLER SETUP:

In order to enter setup mode, the Left arrow needs to be pressed and held at the end of the start-up screen period (5 seconds after power up). The easiest way to do this is to press and hold the left arrow, briefly depress the reset button and wait for the unit to enter setup mode after 5 seconds.

Setup mode allows the installer to adjust:

- Area assignments for each connected slave
- The name displayed to describe each area
- The title displayed on the main menu
- The display turn off delay period

Slave area assignments:

Each of the 64 DMX slave addresses can be assigned to one of the 8 areas. To do this, select *SLAVE AREA ASSIGN* and press the right arrow. Then select the slave address number to assign and press the right arrow again. Select the area to assign the chosen slave address to and press the left arrow when done. Repeat this for each connected slave device.

Area names:

The name of each area can be modified. Each name can be up to 16 characters long. To do this, select *EDIT AREA NAME* and press the right arrow. Select the area whose name is to be changed and press the right arrow again. This will display the name edit screen.

To edit the name, use the right arrow to select the character to edit, then use the up and down arrows to change the character. Press the left arrow when done to exit the name edit screen. Repeat this for each area as necessary.

The default name for each area is "AREA 0" for area 0, "AREA 1" for area 1, and so on.

Menu title:

The title displayed on the main menu can also be modified from the default name "M-ELEC LIGHTING". To do this, select *EDIT MENU TITLE* to display the menu title edit screen.

To edit the title, use the right arrow to select the character to edit, then use the up and down arrows to change the character. Press the left arrow when done to exit the title edit screen. Repeat this for each area as necessary.

Screen off delay:

The display used in the ML-LCD-DMX is an Organic LED type, the very latest in display technology, and features high contrast, a wide viewing angle and rich colours. The only drawback with this technology, as opposed to others like LCD, is that static images will tend to 'burn' into the display if left too long.

To minimize the effects of image burning, the ML-LCD-DMX has an automatic screen off timer that will turn off the display if no buttons are pressed. The timer can be set to anywhere from 5 to 255 seconds, although a value of around 20 seconds is recommended for optimum display life.

The screen off timer is continually counting, but is reset whenever a button is pressed, so a screen off delay of 10 seconds means that the display will remain on for 10 seconds after a button is pressed. If another button is pressed before the 10 seconds is up then the timer will start again and it will take a further 10 seconds for the display to turn off.

To exit setup mode, simply press the left arrow whilst on the setup mode screen. The unit will then save all of the settings into onboard flash memory IC so that the settings can be retained in the event of power loss.

OPERATION:

The ML-LCD-DMX master can control up to 8 separate areas, with each area running on its own "program". The installer will give each area a name for ease of identification.

Screen Layout

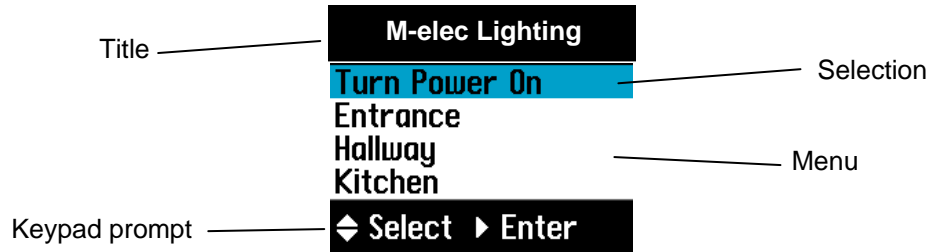

This is the layout of the standard menu screen. Whilst the menu area of some screens may differ from this, the title and keypad prompt areas will always be present. There are four main parts to the menu:

Title

The title area at the top of every screen displays the current menu system. The main menu title factory default is "M-ELEC LIGHTING", as shown, but the installer can modify this to whatever is desired.

Keypad Prompt

The keypad prompt area is a guide to what pressing each of the four arrow buttons on the keypad below the display will do. If a particular arrow is missing then pressing that arrow button will have no effect.

Menu

This area is where any selectable menu options of settings are displayed. Some screens will feature a list of menu options; others will have *gradient sliders* (discussed below) for changing things like colours, fading speed, etc.

Selection

On all menu option lists the selected item is indicated by highlighting that line with a blue background.

Note that if there are more menu options available than will fit on the screen, the option list will automatically scroll down when the down arrow button is pressed past the last line (and vice versa to scroll back up).

	<p>Main Menu</p> <p>The main menu allows power for the entire system to be controlled from a single point and also gives access to the controls for each of the 8 individual areas. The up and down arrows are used to select a menu item, as indicated by the blue highlight. Pressing the right arrow will have a different effect depending on what menu item is selected.</p>
	<p>Power</p> <p>Pressing the right arrow whilst the power option is selected will change the power state. If power is off then the option will show "Turn Power On" and similarly when the power is on then the option will show "Turn Power Off". Note that in order for individual areas to turn on they must have their individual power control turned on.</p>

Area names

Pressing the right arrow with any area name selected will enter into the menu for that area.

Note that references to power on or off are simply referring to the software state and not the actual DMX control system. Under normal operation, the entire system is always powered and a DMX signal is always present. Turning power off from the main menu and/or area menu simply tells the DMX slaves controlling that area to turn off all of their connected lighting.

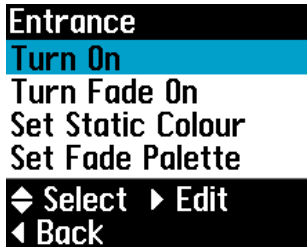

Area Menu

It is the area menu that allows all of the settings for a single area to be controlled.

Power

The power option will display "Turn On" or "Turn Off" depending on the state of that area's power. Note that turning on an area will also turn on the main power control, as found on the main menu, thus allowing the selected area (and any other with their power turned on) to power up.

Fade

Pressing the right arrow when fade is selected will turn on or off colour fading for that area.

Set Static Colour

Selecting the set static colour menu will enter the colour setting screen where the output colour for that area can be set. Note that if fading is turned on then the static colour menu option will turn grey and the menu cannot be entered.

Set Fade Palette

Selecting the set fade palette menu will enter the fade palette setting screen where the palette of colours used in fading can be specified.

Set Fade Speed

Pressing the right arrow with set fade speed selected will enter the menu for controlling the speed of colour fading.

Set Dimming Level

The dimming level menu allows the brightness of the lights in that area to be adjusted without impacting the colour.

Pressing the left arrow button will go back to the main menu.

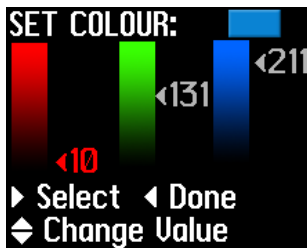

Static Colour Menu

The set colour menu is used to set the static (non-fading) colour of that area. There is one *gradient slider* for each of the red, green and blue channels; the arrow and number beside each gradient indicates the value for that colour channel. Each slider can be adjusted from 0 to 255 (0 = off, 255 = on full brightness) and the combination of these 3 sliders can be used to recreate any colour.

By pressing the right arrow button, each of the red, green and blue values can be selected and subsequently modified by pressing the up and down arrows. The following is a list of some basic colours:

- Red: *Red 255, Green 0, Blue 0*
- Orange: *Red 255, Green 128, Blue 0*
- Yellow: *Red 255, Green 255, Blue 0*
- Light Green: *Red 128, Green 255, Blue 0*
- Green: *Red 0, Green 255, Blue 0*
- Light Blue/Cyan: *Red 0, Green 255, Blue 255*
- Blue: *Red 0, Green 0, Blue 255*
- Purple: *Red 128, Green 0, Blue 255*
- Pink: *Red 255, Green 0, Blue 255*

Pressing the left arrow will return to the area menu.



Set Fade Palette

There are four fade palette options, each with a preset range of colours. The fade colour sequences are as follows:

All Colours

Red – yellow – green – blue – purple – red.

Warm Colours

Red – yellow – pink.

Cool Colours

White – green – cyan – blue.

Pastel Colours

Soft red – soft yellow – soft green – turquoise – sky blue

To select a fade palette simply press the up/down arrow buttons until the desired palette is highlighted. Press the left arrow to return to the area menu.

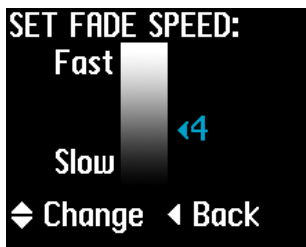

Set Fade Speed

The fade speed is a value between 0 to 15, where 0 is slowest and 15 is fastest. At the slowest speed it will take a few minutes to change from one colour to the next in a fade sequence. At the fastest speed the entire colour fade sequence will be covered in less than 1 minute.

To set the fade speed simply use the up and down arrows to move the gradient slider to the desired speed. Then press the left arrow to return to the area menu.

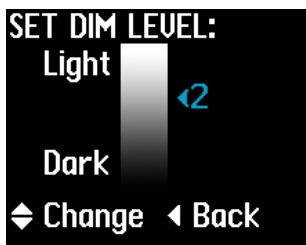

Set Dimming Level

The dimming level affects the overall brightness of that area. A dimming level of 0 is normal brightness (no dimming) and a dimming level of 5 is maximum dimming. At higher dimming levels (4 or 5) flicker may become noticeable as a side effect of the dimming process but this is not a problem at lower levels.

To select the dimming level simply use the up and down arrow buttons to move the gradient slider to the desired setting. Then press the left arrow button to return to the area menu.

Please visit our website for full warranty/disclaimer information or contact your supplier for further information